

**DIY HYBRID SUPER**  
**MODIFYING A LANGSTROTH BOX FOR FLOW® FRAMES**

The following steps are a guide for modifying a standard 8 or 10 frame Langstroth box to allow you to fit Flow® Frames. It should take you 1 to 2 hours to complete.

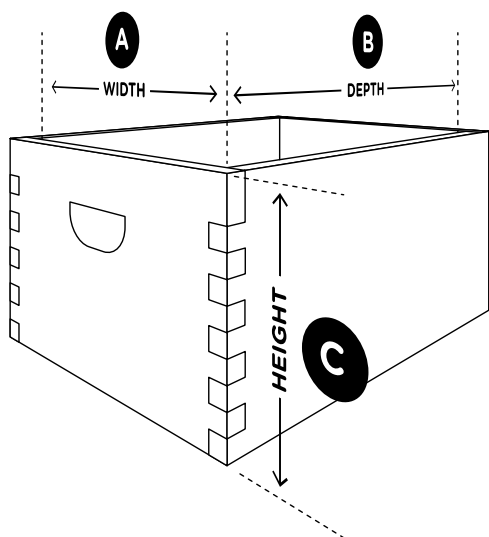

Measurements are for standard Langstroth boxes

	INTERNAL MEASUREMENTS		
	A	B	C
8 frame box	310mm 12 3/16"	465mm 18 5/16"	245mm 9 5/8"
10 frame box	362mm 14 1/4"	465mm 18 5/16"	245mm 9 5/8"

## CONTENTS

<b>1</b>	<b>DIY HYBRID SUPER MODIFICATIONS</b>	
	- 3 OR 4 FLOW FRAMES	2
	- 6 OR 7 FLOW FRAMES	3
<b>2</b>	<b>POSITIONING SCREWS - FRONT</b>	4
<b>3</b>	<b>POSITIONING SCREWS - BACK</b>	5
<b>4</b>	<b>POSITIONING SCREWS - FRONT</b>	6
<b>5</b>	<b>POSITIONING SCREWS - BACK</b>	7
<b>6</b>	<b>CLOSE TOP GAP</b>	8
<b>7</b>	<b>CLOSE BOTTOM GAP</b>	9
<b>8</b>	<b>OBSERVATION WINDOW</b>	10
<b>9</b>	<b>TELESCOPING LID MODIFICATIONS</b>	11
<b>10</b>	<b>DOOR AND WINDOW COVERS</b>	12
<b>11</b>	<b>SET UP YOUR HIVE</b>	13

▶ Go to [www.honeyflow.com](http://www.honeyflow.com) to view a video of the instructions for modifying a Langstroth box for Flow® Light.

# 1 DIY HYBRID SUPER: MODIFICATIONS

8 FRAME LANGSTROTH SUPER

Cutouts required to fit 3 Flow Frames

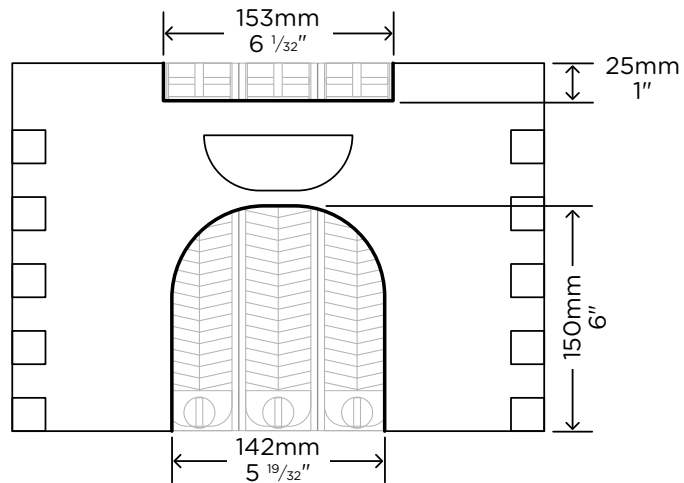

Cutouts required to fit 6 Flow Frames

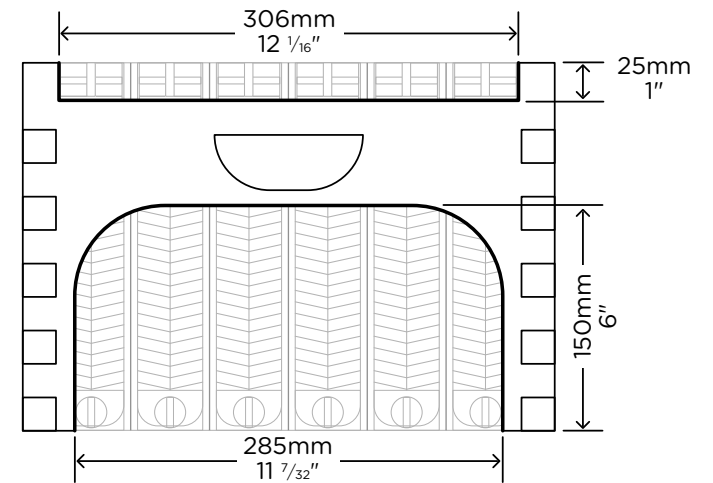

10 FRAME LANGSTROTH SUPER

Cutouts required to fit 4 Flow Frames

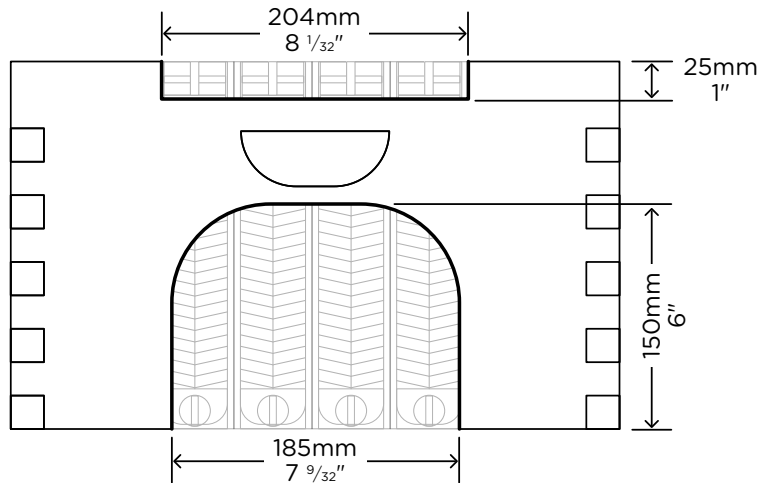

Cutouts required to fit 7 Flow Frames

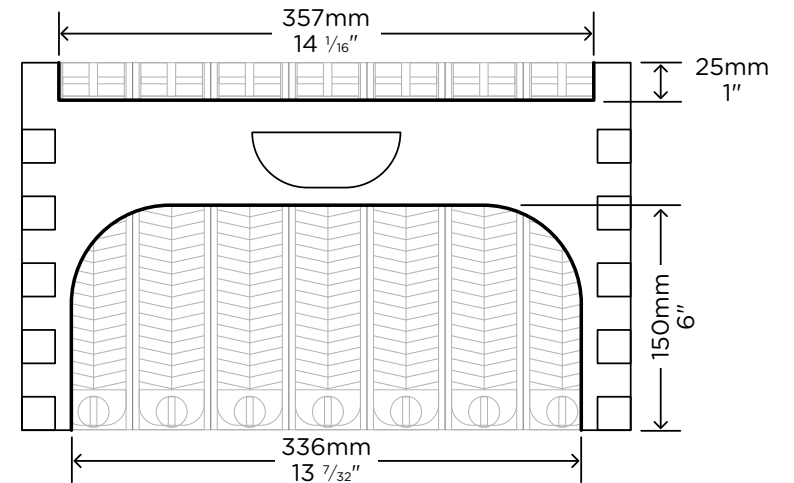

2

### DIY HYBRID SUPER: POSITIONING SCREWS - FRONT

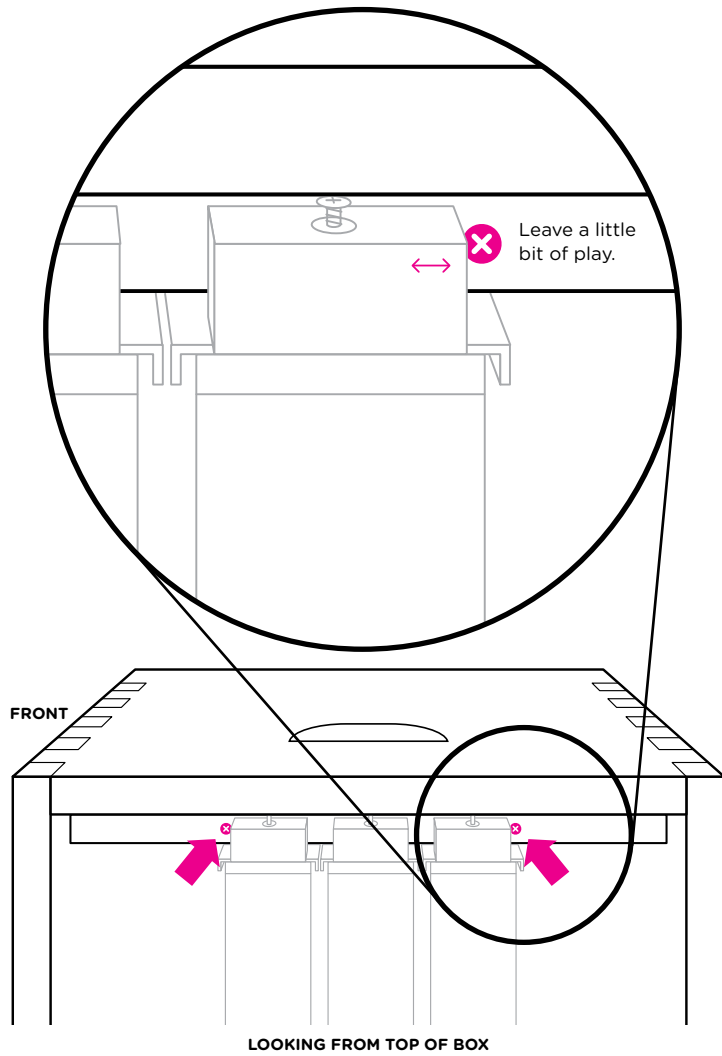

Insert screws on each side of the frames to hold them in place. Leave a little bit of play so the frames are easier to lever out with the hive tool.

3

### DIY HYBRID SUPER: POSITIONING SCREWS - BACK

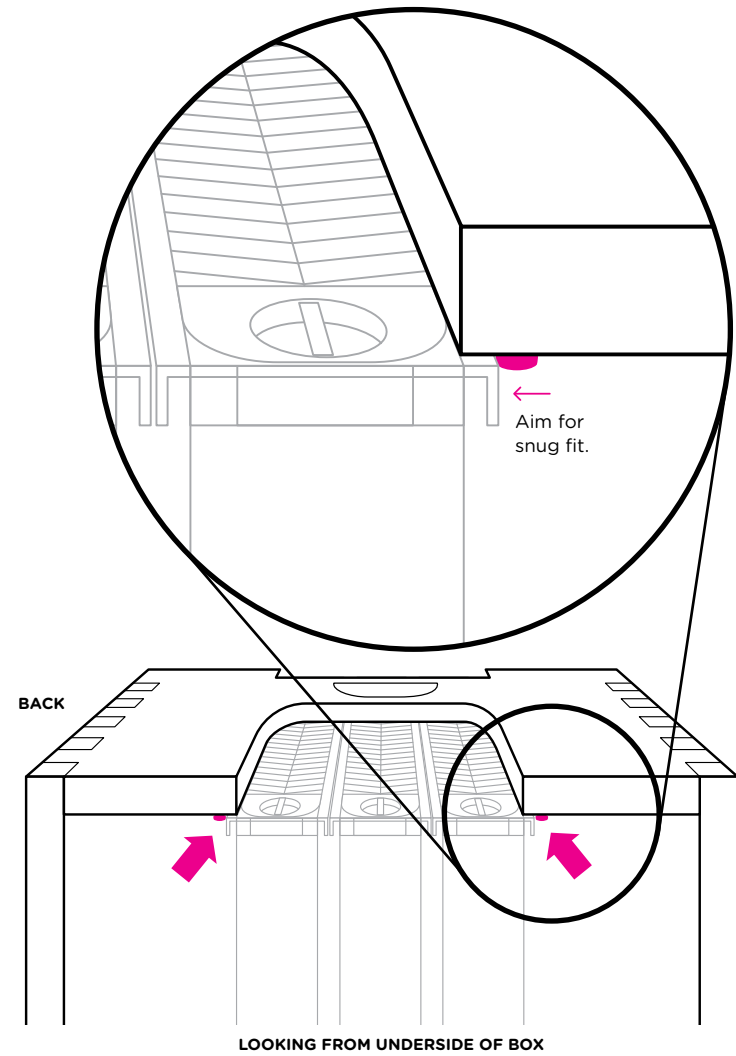

Turn the box over and insert screws on the inside back wall of the hive body on each side of the frames to take up the play, and keep the frames tight together.

4

### DIY HYBRID SUPER: POSITIONING SCREWS - FRONT

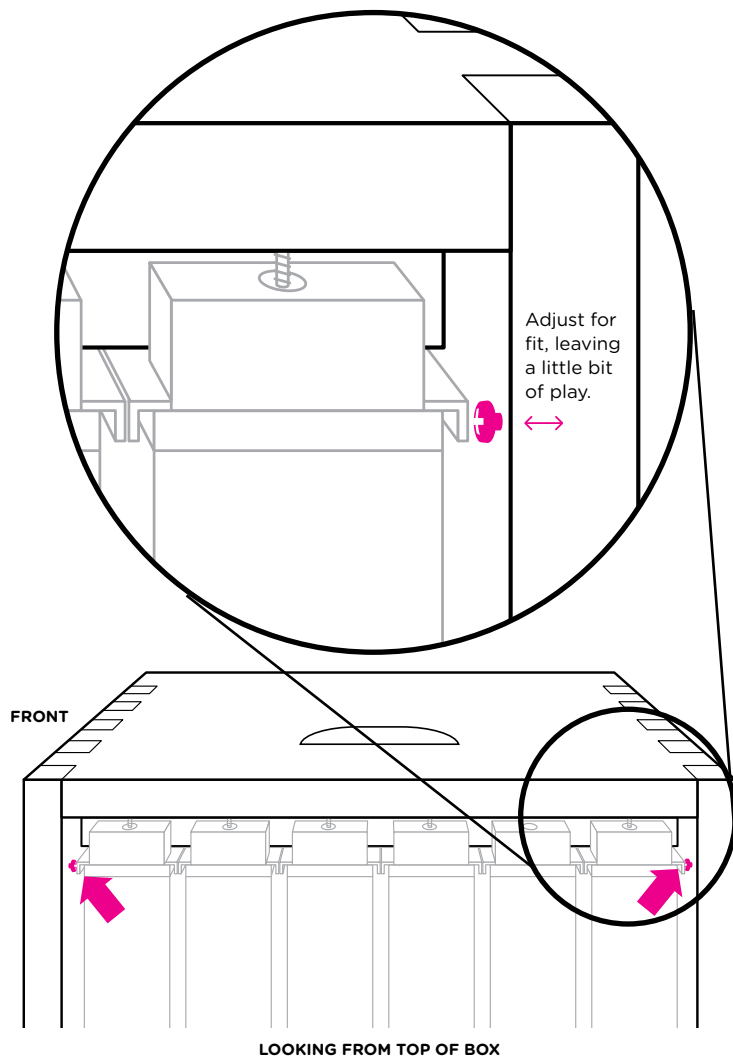

Insert screws on the side wall at the front on each side of the box. Leave a little bit of play so the frames are easier to lever out with the hive tool.

5

### DIY HYBRID SUPER: POSITIONING SCREWS - BACK

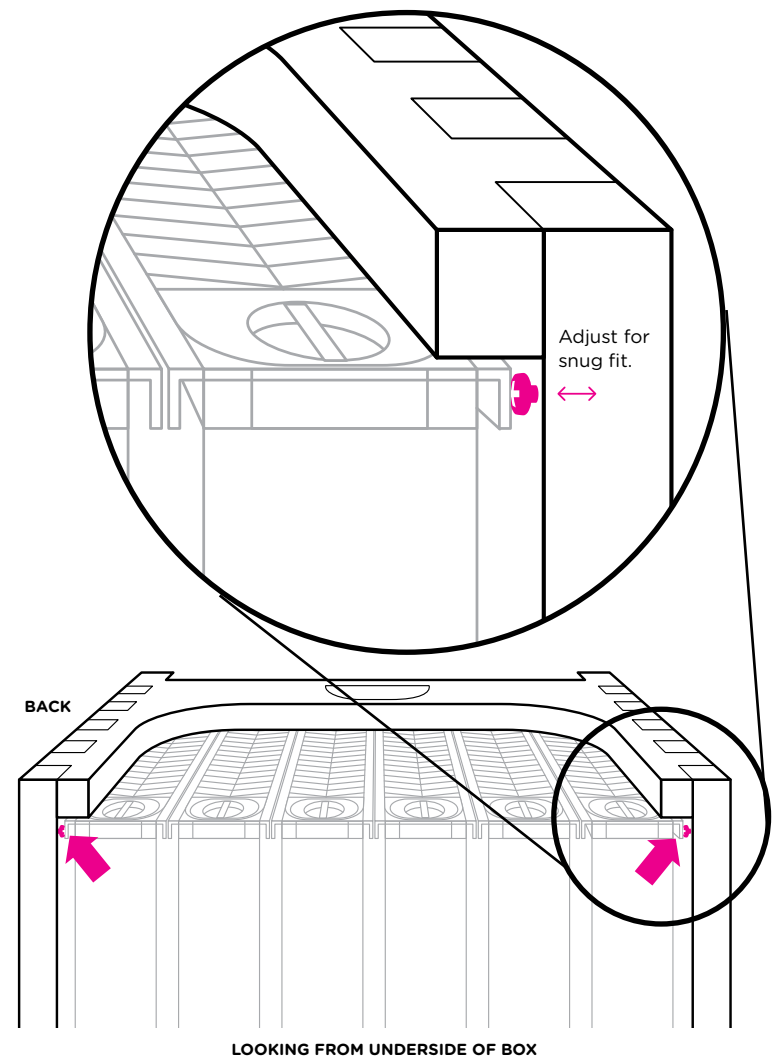

Turn the box over and insert screws on the side wall at the back on each side of the box to take up the play and keep the frames tight together.

6

### CLOSE TOP GAP

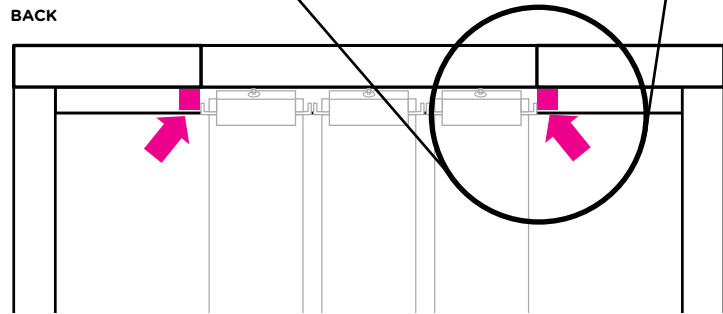
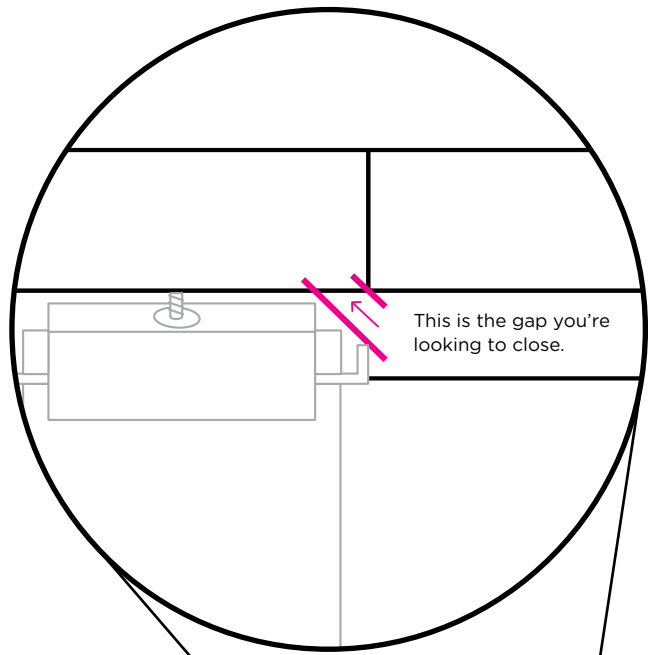

LOOKING FROM TOP OF BOX

Close up the gap between the frames and the tool access opening by gluing on two small blocks of wood.

7

### CLOSE BOTTOM GAP

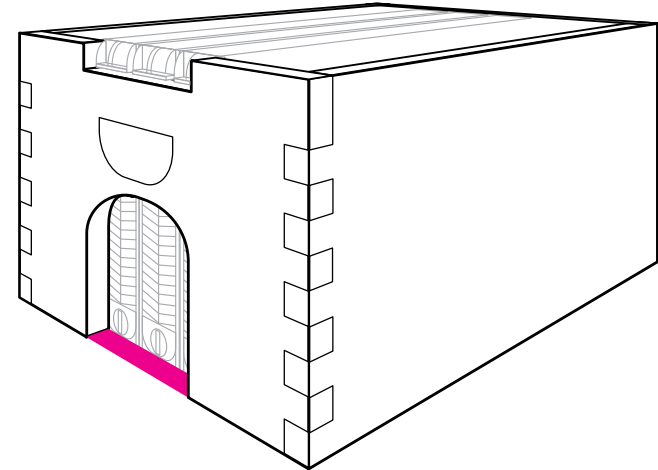

If you are modifying your hive body for Flow® Light (3-4 frames), cut out a thin piece of plastic or wood to fit into the bottom of the opening, blocking any gap between the frames and box to stop bees getting out.

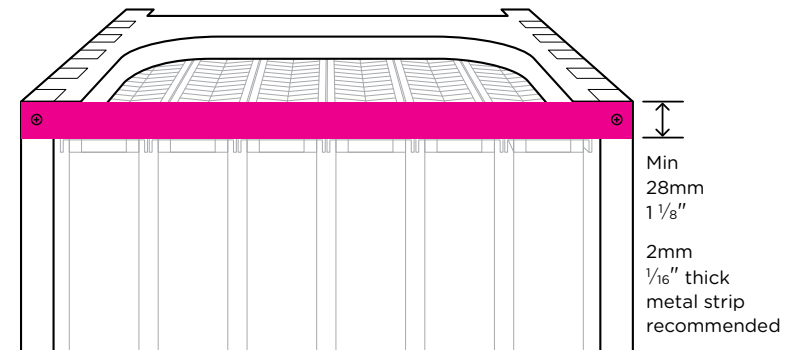

If you are modifying your hive body for Flow® Full (6-7 frames), screw a metal strip to the bottom of the hive body. This will cover the gap and also provide additional strength to the hive body. The metal strip can be notched into the box. Make sure the gap between the bottom of the frames and the metal strip is less than 3mm / 1/8" so bees can't escape when the door is opened.

# 8

## OBSERVATION WINDOW

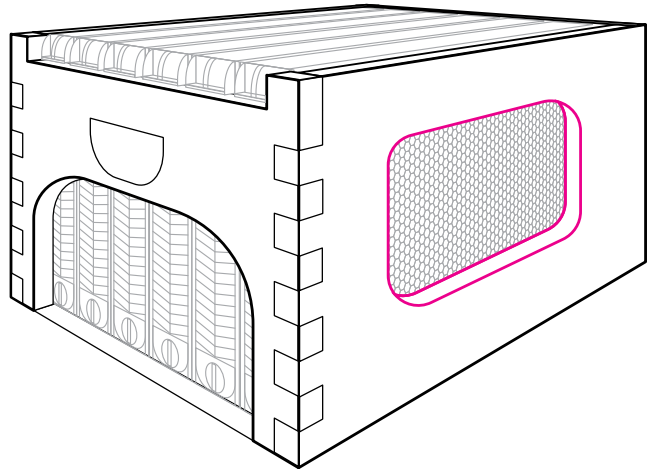

An observation window on the side is not essential. If you do make one, it's important that the clear acrylic/glass sits flush with the inside wall of the box as there's not much room once the frames are in there. We recommend cutting your window shape and then rebating a larger area to allow for flush mounting the clear acrylic/glass. Screws with washers or glue could be used around the edge to hold glass in place.

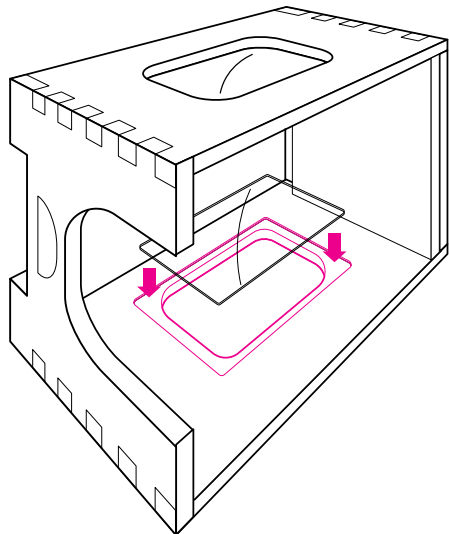

# 9

## TELESCOPING LID MODIFICATIONS

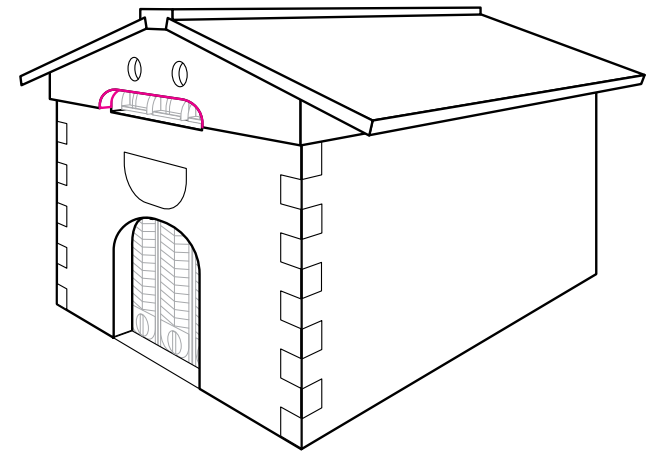
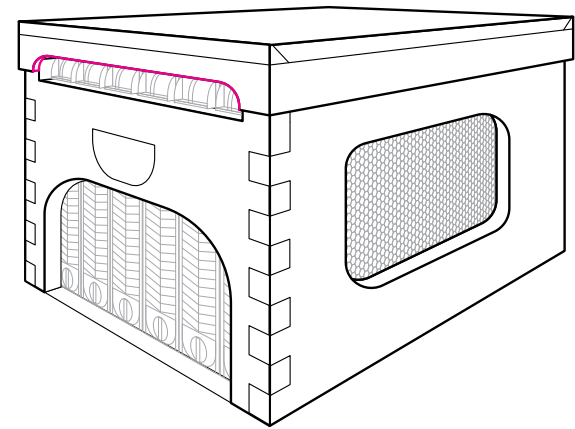

Some lids such as the telescoping lids will need to be modified to allow access for the Flow® tool. You can achieve this by cutting away some of or all of the overlapping part of the lid on the rear side. Cut this window slightly wider than the opening in the hive body. This will allow for any misalignment when you put the lid back on the hive body. Exactly where the cutout is situated will depend on the specific dimensions of your lid.

# 10

## DOOR AND WINDOW COVERS

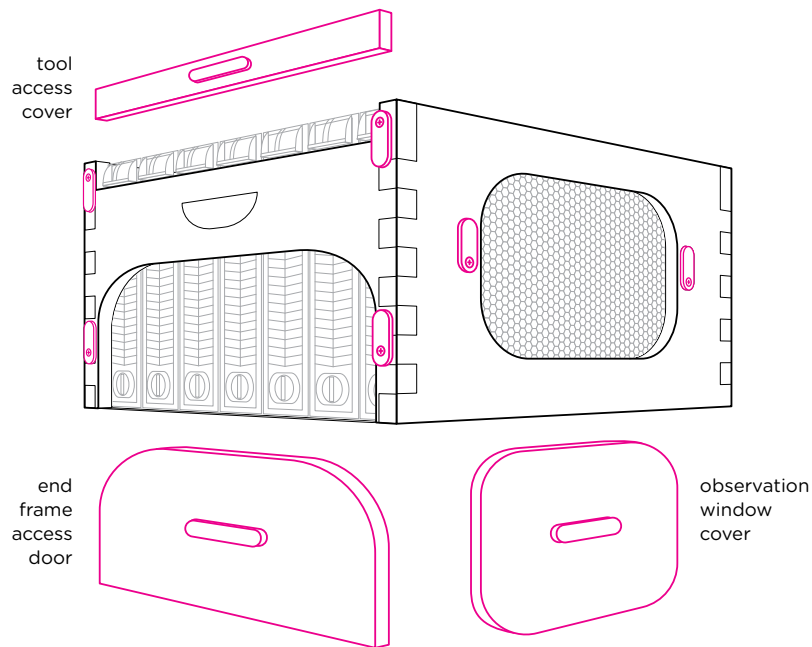

Create the covers for the tool access, end frame access and observation window. You should be able to use the piece you cut out for the end frame access door (you may need to trim the bottom to allow for whatever gap covering you have used in step 8).

You will probably need to make new pieces for the tool access cover and observation window cover. Plane these so they sit flush with the box (optional).

Make handles for each of the covers. These can simply be nails or screws or make and attach wooden ones.

To ensure the covers stay in place add some latches. Latches can be as simple as bent nails, eyehooks or small wooden pieces.

# 11

## SET UP YOUR HIVE

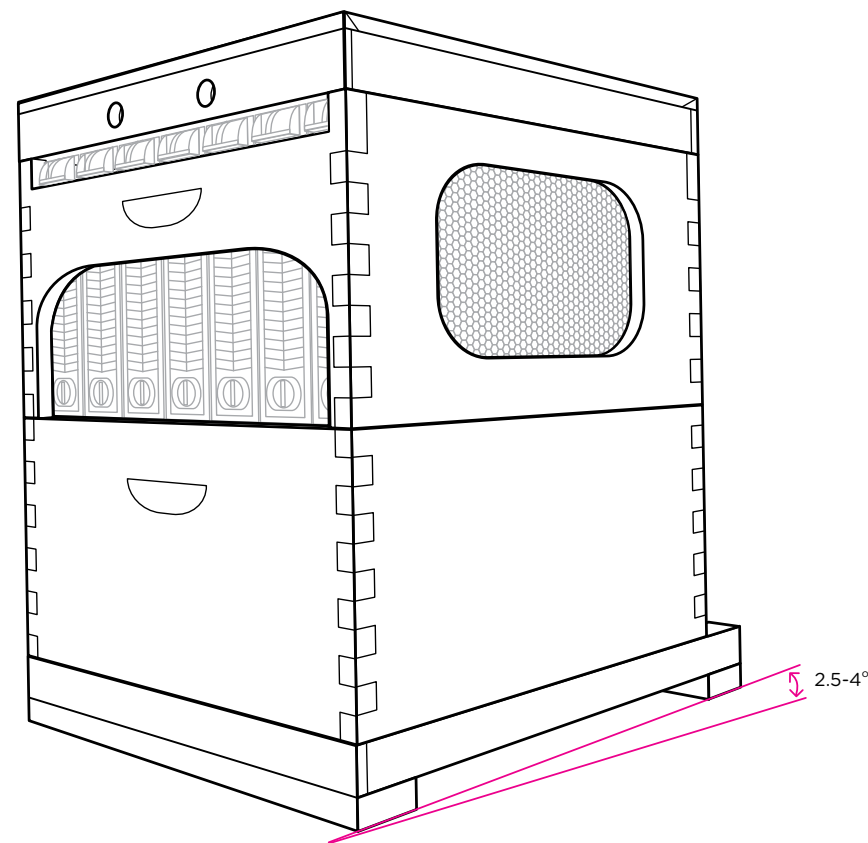

The slope of the hive for optimal draining is 2.5-4 degrees sloping backwards. Either chock the hive when it's time to drain, or ideally, leave the hive on a permanent slope. However, it's important to make sure that water can't get into the front. A sloping landing board can minimize this.





**HONEYFLOW.COM**